

CLUTCH / PRIMARY DRIVE

PRIMARY CASE ASSEMBLY

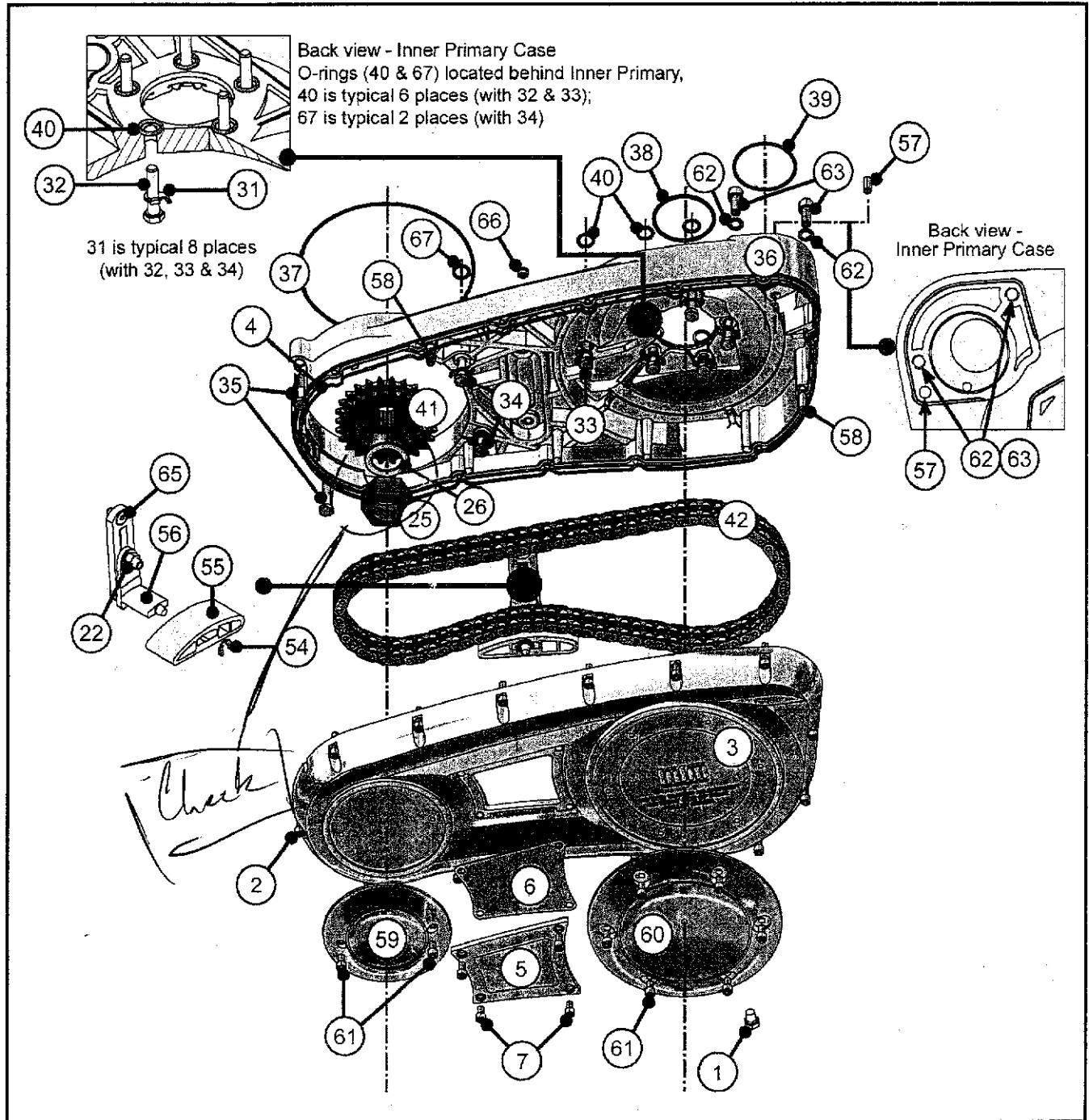

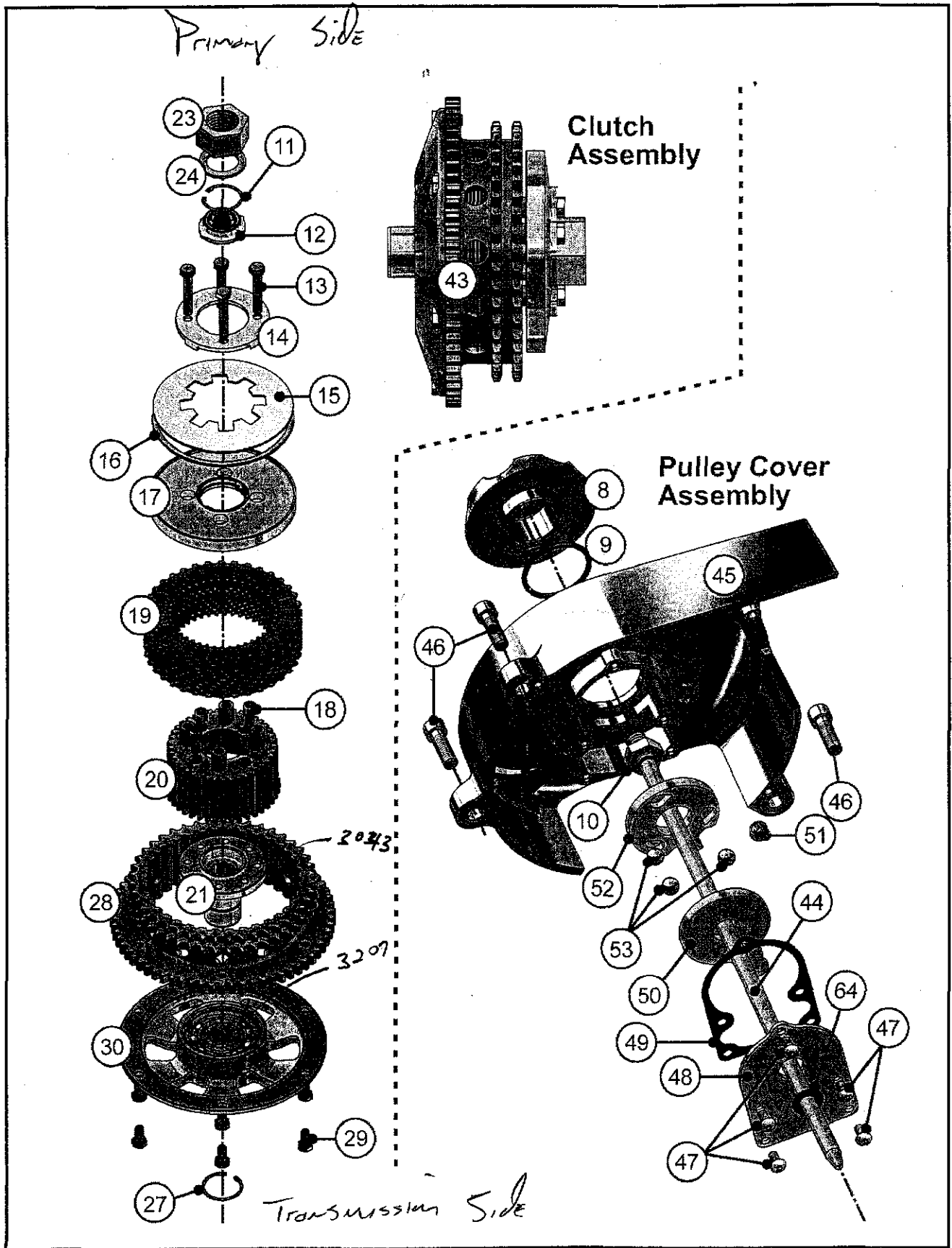

PRIMARY ASSEMBLY PARTS LIST

INDEX	DESCRIPTION	QTY.
1	Drain plug, 3/8-24	1
2	Primary cover screws 1/4-20 x 1" SHCS	14
3	Outer primary	1
4	O-ring, inner-to outer primary	1
5	Inspection cover	1
6	Gasket, inspection cover	1
7	Inspection cover screws 1/4-20 x 1/2" SHCS, SS	4
22	Chain adjuster nut	1
25	Engine sprocket nut, 7/8-14	1
26	Engine sprocket washer	1
31	Locking tab	8
32	Primary trans screw 5/16-18 x 1-1/4"	5
33	5/16-18 x 1-1/2" hex	1
34	Zero-offset primary 5/16-18 x 1-3/4" hex SHCS 1/2"-offset primary 5/16-18 x 2-1/4" hex SHCS	2
35	Primary engine screws 1-1/4" for zero offset primary, 1-1/2" for 1/2" offset primary	2
36	Inner primary, zero offset, or Inner primary, 1/2" offset	1
37	O-ring, primary to engine	1
38	O-ring, primary to transmission	1
39	O-ring, starter	1
40	O-ring, primary to transmission, small	6
41	Engine sprocket, 29-tooth zero offset	1
42	Chain, 428-2 double row	1
43	Clutch assembly	1
54	External snap ring, 10 mm	1
55	Tensioning shoe	1
56	Chain adjuster assembly	1
57	Dowel, starter 5/16 x 3/4"	1
58	Dowel pin, primary 1/4 x 3/4"	2
59	Engine sprocket cover	1
60	Derby cover	1
61	Screws, 1/4-20 x 1/2" SHCS, SS	8
62	3/8" lock washer, SS, polished	2
63	3/8-16 x 1-3/4" SHCS polished	2
64	Wiper	1
65	Chain adjust screw 5/16-18 x 7/8" FHCS	2
66	Vent fitting w/ washer	1
67	O-ring, primary to engine	2

CLUTCH ASSEMBLY PARTS LIST

INDEX	DESCRIPTION	QTY.
11	Retaining ring, keyhole fitting	1
12	Throw-out bearing assembly	1
13	Pivot plate screws 5/16-18 x 2" hex	4
14	Clutch pivot plate	1
15	Clutch diaphragm spring	1
16	Seat, diaphragm spring	1
17	Pressure plate	1
18	Flanged hub screw 5/16-18 x 3/4" SHCS	4
19	Clutch pack	1
20	Inner hub	1
21	Flanged hub	1
23	Clutch nut (left-hand thread)	1
24	Washer, clutch nut, 1 inch I.D.	1
27	Retaining clip, 35 x 2.50 mm	1
28	Outer hub w/sprocket	1
29	5/16-24 x 5/8" hex screw, clutch carrier	6
30	Bearing carrier	1

PULLEY COVER/CLUTCH PUSHROD PARTS LIST

Index	Description	Qty.
8	Clutch adjust cover	1
9	Pushrod release cover O-ring	1
10	Clutch pushrod jam nut	1
44	Clutch pushrod	1
45	Pulley cover	1
46	Pulley cover screws 5/16-18 x 1" SHCS	3
47	Inner access cover mounting screws	5
48	Inner access cover	1
49	Inner access cover gasket	1
50	Inner ramp	1
51	Ferrule	1
52	Outer ramp	1
53	Ball bearings	3

FLUIDS

Primary fluid	32 oz.
---------------	--------

TORQUE VALUES

NOTE: All fasteners are Grade 5 or above.

DESCRIPTION	TORQUE	LOCTITE
Primary drain plug	48 in•lbs (4 ft•lbs)	None
Outer primary screws	100 in•lbs (8 ft•lbs)	222 with 7649 primer N
Inspection cover screws	108 in•lbs (8 ft•lbs)	None
Ring gear screws	20 ft•lbs	2760
Primary transmission screws	14-16 ft•lbs	2440
Engine sprocket nut	150 ft•lbs	2760
Clutch hub nut	80 ft•lbs	2760
Clutch hub screws	20 ft•lbs	2760
Pivot plate screws	20 ft•lbs	2760
Inner access cover screws	24 in•lbs (2 ft•lbs)	2440
Pulley cover screws	20 ft•lbs	2760
Chain adjuster nut	25 ft•lbs	N/A
Starter screws	20 ft•lbs	N/A
Derby cover screws	7-9 ft•lbs	222 with 7649 primer N
Sprocket cover screws	6 ft•lbs	2440
Primary engine screws	20 ft•lbs	2440
Chain adjust screws	20 ft•lbs	2760
Clutch pivot screws	20 ft•lbs	2440
Vent fitting	8-10 in•lbs	2440
Clutch pushrod nut	30 ft•lbs	None

NOTE: Thoroughly clean threads of all screws removed prior to assembly. Thoroughly clean internal threads at all screw locations. Use Loctite products as indicated. Use torque values specified.

BATTERY DISCONNECT

NOTE: Before performing any of the following procedures, disconnect battery, ground cable first.

WARNING! To prevent sparking, always disconnect ground cable first and reconnect last. Sparks may cause flammable substances to ignite or explode.

CLUTCH ADJUSTMENT

NOTE: Make all clutch adjustments with the system at ambient temperature.

Support the motorcycle upright and level.

Slide clutch cable adjuster boot away from adjusting hardware.

Turn clutch cable adjuster to provide maximum slack in cable.

Remove clutch adjust cover (8) and O-ring (9).

Loosen clutch pushrod jam nut (10).

NOTE: Only light force is needed to seat pushrod.

Turn clutch pushrod clockwise with a 7/32" Allen wrench to remove all free play, then turn clutch pushrod 1/4-turn, counter-clockwise.

Keep pushrod from rotating with a 7/32" Allen wrench and tighten jam nut.

NOTE: Thoroughly clean the clutch adjust cover (8), removing all oil and residue from the seat area and cap. Install when dry to prevent part from vibrating loose.

Install clutch adjust cover.

NOTE: Lubricate clutch cable with a dry-film lubricant such as Bike-Aid.

Adjust clutch cable at adjuster to provide 1/16" free play between clutch lever and clutch lever housing..

Tighten clutch cable adjuster locknut.

Slide clutch cable adjuster boot over hardware.

INSPECTION COVER REMOVAL

Remove four inspection cover screws (6).

NOTE: Inspection cover removal is accomplished by using a pick through a screw hole to pry cover free from outer primary following screw removal.

INSPECTION COVER INSTALLATION

NOTE: Remove all of the old sealing material from the inspection cover, and from around the opening in the outer primary. All sealing surfaces must be free of oil and dry.

1. Before installing the primary inspection cover gasket, spread a small layer of Loctite 5699 RTV Silicone Sealer onto the face of the primary opening as shown below. Spread sealer to ensure continuous surface coverage.

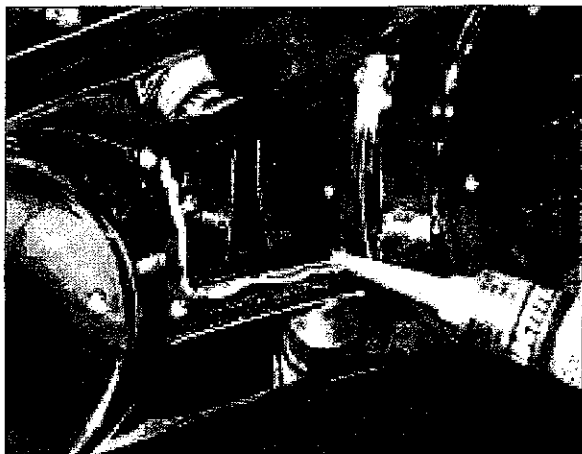

Typical – Spread sealant around opening.

- Place gasket onto opening as shown in next image.

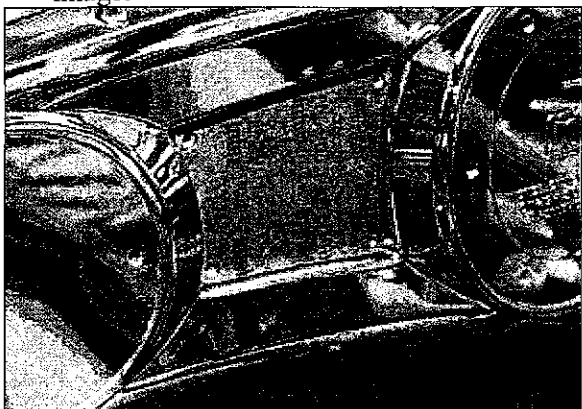

Typical.

- Install inspection cover screws and hand tighten with **no** Loctite used. Torque the inspection cover screws to 54 **in•lbs** using the sequence shown below. Give a final torque of the screws to 108 **in•lbs** using the same sequence.

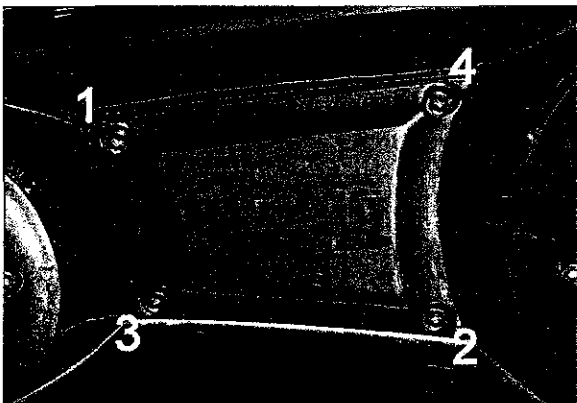

Typical – Torque pattern.

OUTER PRIMARY - REMOVAL AND INSTALLATION

Remove primary case drain plug (1) and drain primary fluid.

Remove the fourteen 1/4" perimeter screws (2) and the outer primary (3). Installation is reverse of removal. Pay attention to torque sequence. Make sure O-ring (4) is properly seated in groove. Replace O-ring if damaged. Apply Loctite 222 and primer N to screws before installation.

Torque to 100 **in•lbs** (8 **ft•lbs**).

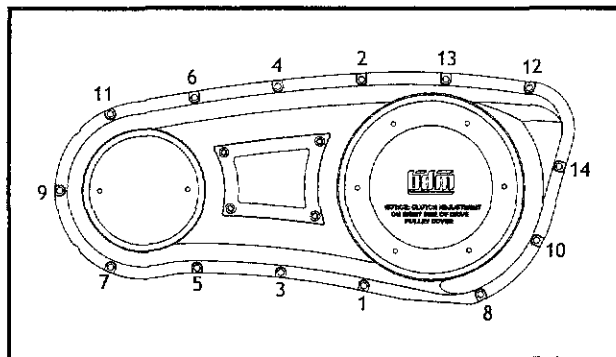

Outer primary torque sequence.

Install primary drain plug. Torque to 70-75 **in•lbs** (6 **ft•lbs**).

Remove outer primary inspection cover (5) and fill primary with 32 oz. primary drive lubricant.

CLUTCH DOME HEIGHT

NOTE: The diaphragm spring dome height range of operation is 0.020 to 0.068".

When dome height of clutch spring exceeds 0.068", replace the clutch pack. Clutch packs are preassembled, pre-oiled and ready to install. It is not necessary to measure pack height or add shims to increase/decrease diaphragm spring dome height.

Measurement for dome height is taken as shown in the next image.

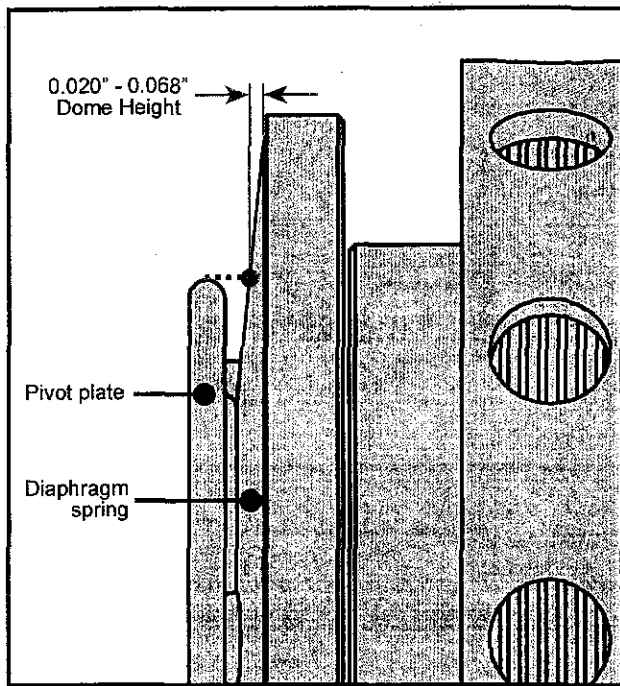

CLUTCH DIAPHRAGM SPRING AND PLATE REMOVAL

CLUTCH PLATE REMOVAL

Loosen clutch pushrod jam nut (10) and clutch cable adjuster.

Remove throw-out bearing assembly retaining ring (11) with snap-ring pliers and discard.

Remove throw-out bearing assembly (12).

Remove four clutch pivot plate screws (13), pivot plate (14), diaphragm spring (15), spring seat (16), and pressure plate (17).

Remove the four, 5/16" socket head hub flange screws (18).

Remove clutch pack (19) and inner hub (20) as a unit.

Clean primary fluid from steel and fiber plates with brake cleaner.

Inspect steel plates for warpage or discoloration, and fiber plates for glazing.

Inspect the splines on the inner clutch hub (20) and basket for wear.

Inspect teeth on the outside diameter of fiber plates for wear.

Inspect inner clutch hub splines for wear. Some wear is normal. If grooves that affect axial

movement of the plates are worn into splines, replace affected parts.

Inspect the portion of the flanged hub (21) which engages the transmission input shaft seal for damage. If damaged, replace the flanged hub.

CLUTCH BASKET/ENGINE SPROCKET/PRIMARY CHAIN - REMOVAL AND INSTALLATION

CLUTCH BASKET REMOVAL

Loosen clutch pushrod jam nut (10) and clutch cable adjuster.

Loosen primary chain adjuster nut (22).

Remove clutch hub nut (*left-hand thread*) (23) and washer (24) using an impact wrench. Remove engine drive sprocket nut (25) and washer (26).

NOTE: For both clutch hub nut removal and engine drive sprocket removal, place a locking tool between engine sprocket and clutch basket gear to lock the primary drive.

Remove engine sprocket (41), chain (42), and clutch assembly (43) as one unit.

FLANGED HUB AND RING GEAR - REMOVAL AND INSTALLATION

NOTE: Installation of new flanged hub is in reverse order of removal.

Remove retaining clip (27) holding flanged hub in bearing carrier.

Support bearing carrier/clutch basket on a hydraulic press and press out the flanged hub (21).

To replace outer hub (28), remove six mounting screws (29) attaching it to the bearing carrier (30).

Place new ring gear on clutch basket. Apply Loctite 2760 to six mounting screws previously removed and torque to 20 ft•lbs.

CLUTCH BASKET INSTALLATION

NOTE: Install engine sprocket (41), chain (42) and clutch assembly (43) as one unit.

Place clutch basket assembly, engine sprocket, and drive chain unit into primary.

Apply two drops of Loctite 2760 to transmission main shaft. Install washer (24) and clutch hub nut

(left-hand thread) (23) and locking tool. Torque to 80 ft•lbs.

With locking tool in place, apply two drops of Loctite 2760 to engine sprocket shaft. Install engine sprocket washer (26) and nut (25). Torque to 150 ft•lbs.

Remove locking tool and adjust primary chain tension.

SETTING PRIMARY CHAIN TENSION

1. Remove outer primary as outlined in *Chapter 4 - Clutch/Primary Drive* in the *2006 Big Dog Motorcycles Service Manual*.

NOTE: Set chain slack at the high side of the tolerance range if possible. Check slack only at the tightest spot.

2. Adjust the chain tension shoe to a point resulting in a slight amount of chain slack and tighten the adjustment bracket nut enough to prevent slippage.
3. To find the tightest spot in the chain, mark a spot on front sprocket (see "A" in image below) and rotate three full turns, continually checking chain tightness as you rotate the assembly. Use the tightest spot for all measurements and adjustments needed.

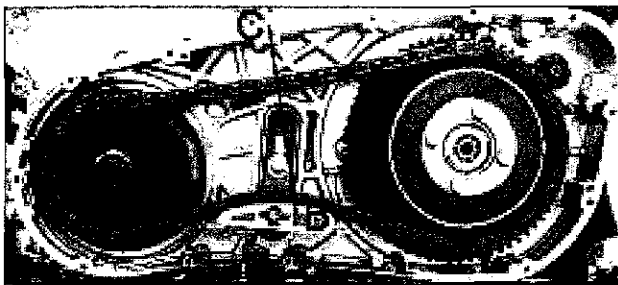

A. Mark on front sprocket.
B. Adjustment shoe measurement location.
C. Top primary bolt hole.

4. To measure downward chain play, place a ruler on top of the adjustment shoe at the intersection of the shoe and the web (B, image above), and the left edge of the top primary bolt hole (C, image above).
5. Apply light (2-3 lbs) downward force with index finger only, at the center of the chain link with ruler in positions A and B below. Take measurement using the left side of ruler.

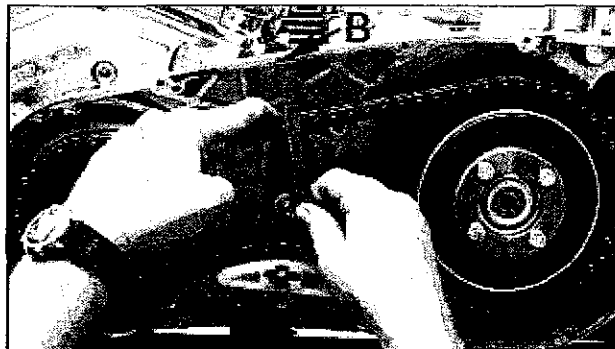

Typical.

6. To measure upward chain play, apply light 2-3 lbs upwards force on the chain with index finger only, at the center of the chain link. Measure from the neutral chain position using the left side of ruler.

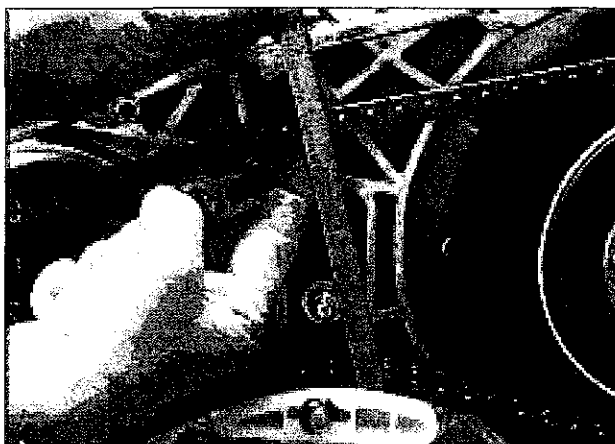

Typical.

NOTE: The difference between measurements will be the chain slack amount of total play.

7. Set the primary chain adjustment to allow for a range of total chain slack at the tightest spot on the chain from 5/8–7/8".
8. Torque the primary chain adjuster locknut (A, next image) to 25 ft•lbs.

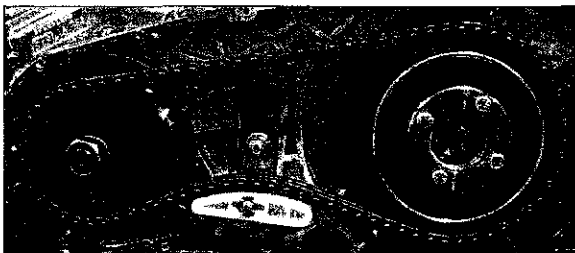

A. Adjuster locknut. Torque to 25 ft•lbs.

9. Check the amount of chain slack and re-adjust if outside of the range given.

NOTE: Chain deflection should be between 5/8" and 7/8" at the tightest position across top of chain with cold engine. Torque chain adjuster nut (22) to 25 ft•lbs. When necessary, replace chain adjuster assembly (56) as a set. When adjusting chain slack with a hot engine, settings should be between 3/8 to 5/8".

Reinstall clutch hub with previously removed screws. Apply Loctite 2760 to screws and torque to 20 ft•lbs.

NOTE: If clutch pack replacement is necessary, the clutch pack comes as a prepared assembly. It is not necessary to measure pack height or add shims to increase/decrease diaphragm spring dome height.

Install clutch pack assembly with 0.120" steel plate towards inside of clutch basket.

NOTE: All steel plates have rounded edges on one side and sharp on the other. In all cases, install plates with sharp edge towards transmission.

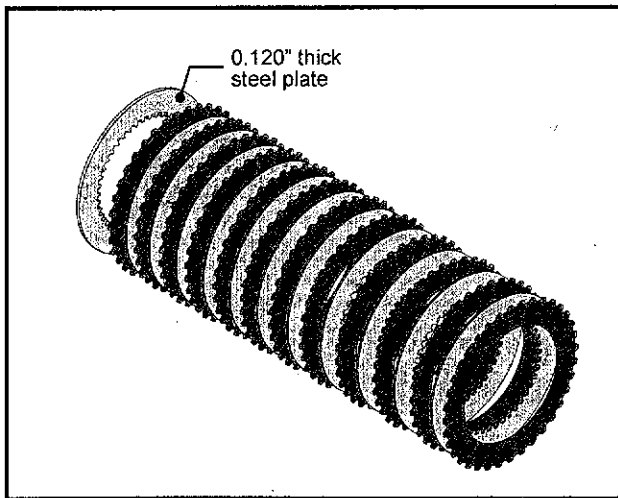

Reinstall pressure plate (17), spring seat (16), diaphragm spring (15) and pivot plate (14). Ensure pivot plate alignment tabs are not obstructing spring plate teeth. Apply Loctite 2760 to threads and torque to 20 ft•lbs.

Reinstall throw out bearing assembly (12) with new retaining ring (11). Ensure clip seats properly.

Adjust clutch.

INNER PRIMARY VENT INSTALLATION

Apply Loctite 2440 to threads of vent (66).

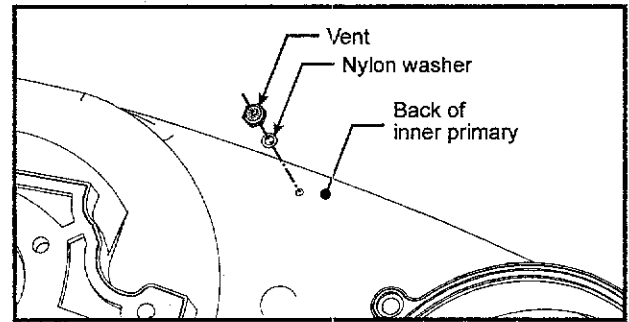

Install vent and nylon washer from the outside of the inner primary. Torque to 8-10 in•lbs.

INNER PRIMARY – REMOVAL AND INSTALLATION

INNER PRIMARY REMOVAL

Disconnect harness wire to starter solenoid.

Disengage locking tabs (31) from the eight screws retaining inner primary to engine and transmission.

Remove six screws (32, 33) retaining inner primary to transmission.

Remove four screws (34, 35) retaining inner primary to engine.

Remove inner primary (36) and starter as an assembly.

INNER PRIMARY INSTALLATION

Inspect and install new O-rings if needed.

- One O-ring, between engine and primary.
- Two O-rings, engine-to-inner primary.
- Six O-rings, transmission-to-inner primary.

Install inner primary/starter assembly to engine and transmission.

Apply Loctite 2440 to threads of primary engine screws (35), and loosely install primary offset screws (34) retaining inner primary to engine.

Loosely install inner primary-to-transmission screws. Ensure that the long, 5/16-18 x 1-1/2" screw is properly located.

Apply Loctite 2440 and torque screws to 20 ft•lbs using torque sequence shown.

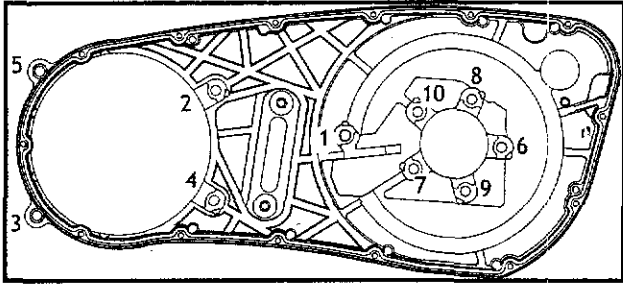

Inner primary torque sequence.

Engage locking tabs.

Reconnect starter wiring.

PULLEY COVER/CLUTCH ACTUATOR

PULLEY COVER REMOVAL

Remove exhaust system.

Fully collapse clutch cable adjuster.

Remove clutch adjust cover (8).

Loosen clutch pushrod jam nut (10).

Remove clutch pushrod (44).

Remove the three socket head screws (46) retaining the pulley cover.

Remove pulley cover (45).

CLUTCH ACTUATOR REMOVAL

Remove five, inner access cover mounting screws (47).

Remove the inner access cover (48) and gasket (49).

Remove inner ramp (50).

Remove ferrule (51) retaining clutch cable end.

Remove outer ramp (52).

Clean and inspect the ramps (50, 52), ball bearings (53), and ferrule (51) for excessive wear. Replace worn parts.

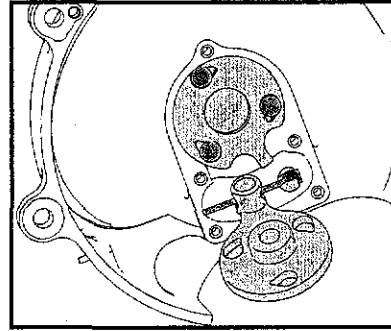

Actuator/ramp assembly.

CLUTCH ACTUATOR INSTALLATION

Installation is opposite of removal.

Position outer clutch release ramp (52) into pulley cover (45).

Pack clutch actuator assembly with bearing grease and position in ramps.

Install cable end and ferrule (51) into inner clutch ramp and position inner clutch ramp into pulley cover.

Pack housing full with bearing grease.

Position inner access cover gasket (49) and inner access cover (48) on clutch release housing and secure with five mounting screws (47). Torque access cover screws to 24 in•lbs (2 ft•lbs).

Remove clutch cable clamp, holding cable to frame.

Lubricate clutch pushrod thoroughly with hi-temp bearing grease and install into actuator using minimal thread engagement (2-3 threads).

Install pulley cover assembly. Apply Loctite 2760 to threads of three pulley cover retaining screws. Torque to 20 ft•lbs.

Adjust clutch.

Chapter
7

TRANSMISSION

TRANSMISSION POWER FLOW DIAGRAM

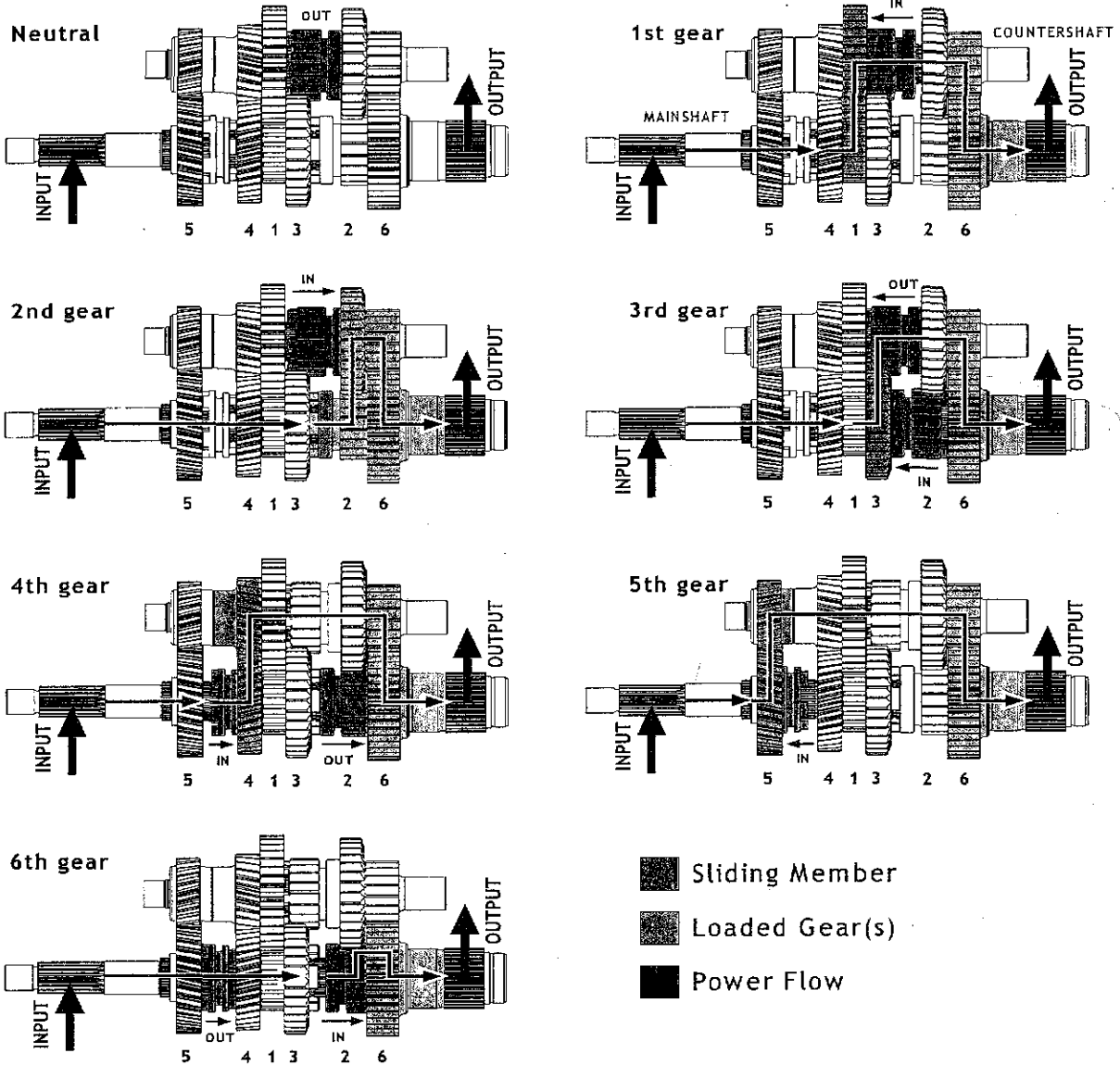

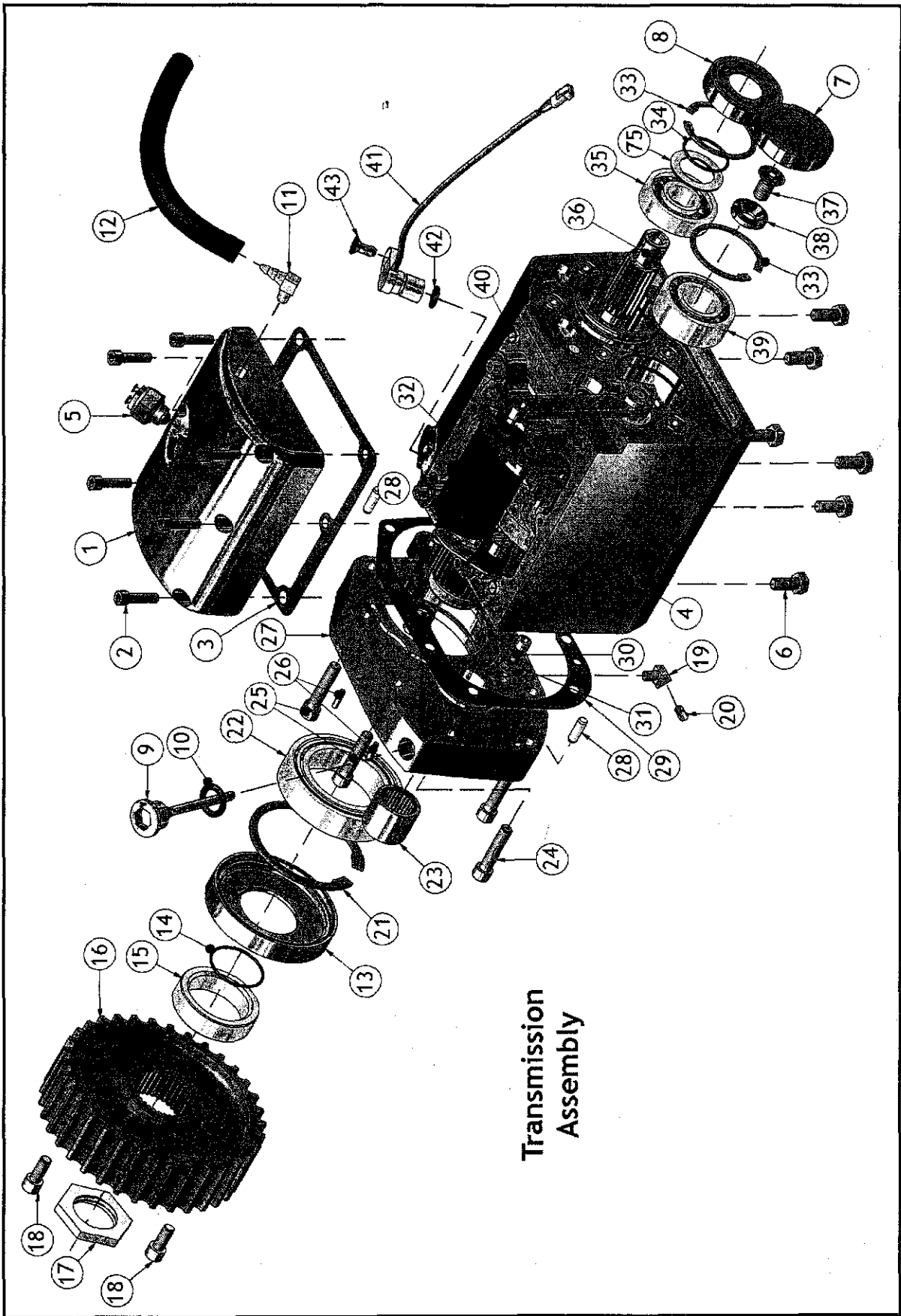

Shift Assembly

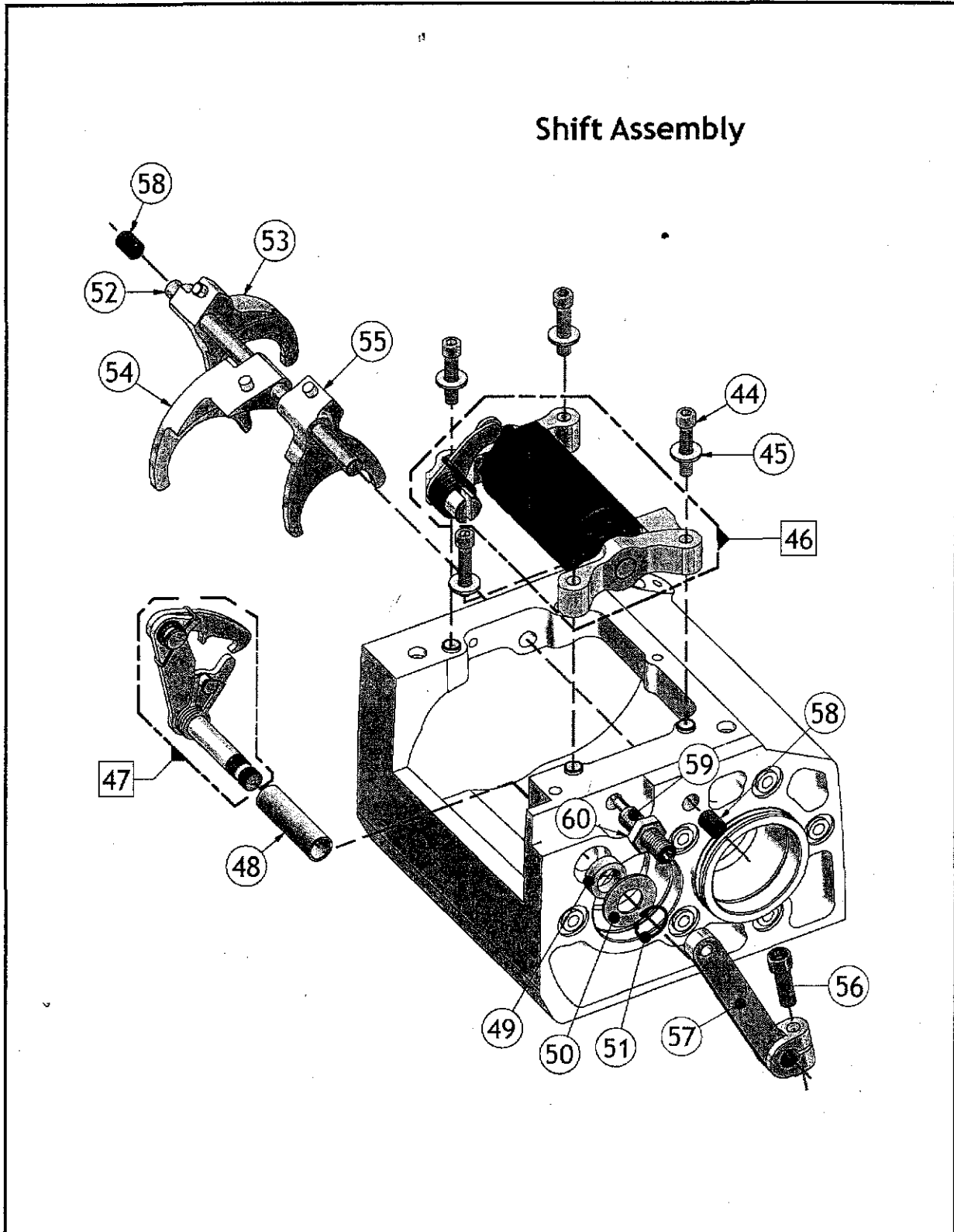

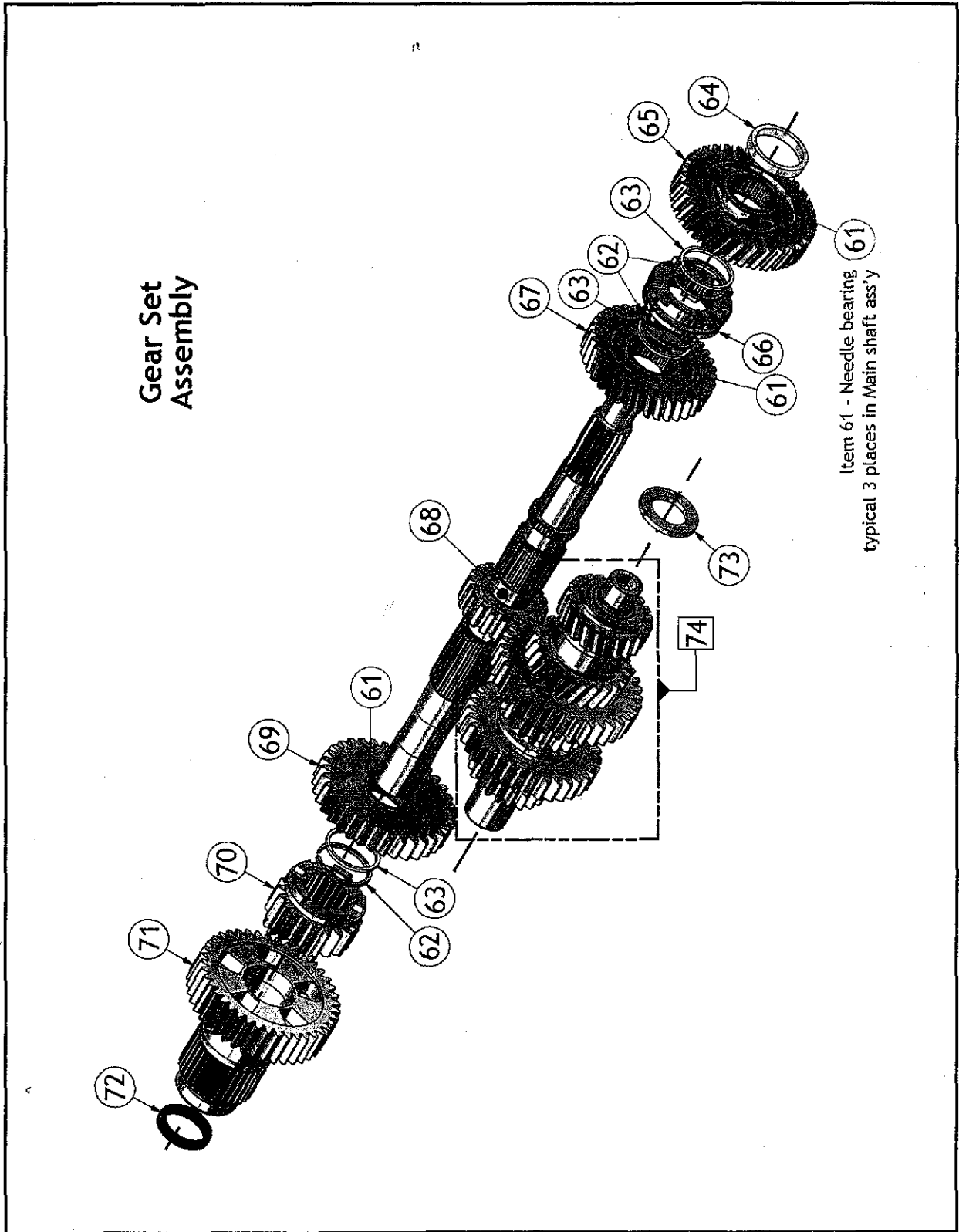

MANUAL TRANSMISSION ASSEMBLY PARTS LIST

ITEM	DESCRIPTION	QTY
1	Top cover	1
2	Top cover screws, 1/4-20 x 1" SHCS, SS polished	6
3	Top cover gasket	1
4	Transmission case	1
5	Neutral switch w/O-ring	1
6	Transmission mounting screws, 7/16-14 x 3/4" flange screw, zinc	6
7	Seal, C/S left side	1
8	Seal, M/S left side	1
9	Filler dipstick	1
10	Filler dipstick O-ring, #115	1
11	90° street elbow	1
12	Vent hose	1
13	Oil seal	1
14	Quad seal	1
15	Pulley spacer	1
16	34-tooth drive pulley	1
17	Pulley nut (left-hand thread)	1
18	1/4-20 x 5/8" SHCS	2
19	45° elbow	1
20	1/8" NPT pipe plug	1
21	Snap ring, 3-11/32" main bearing	1
22	Main bearing, 45 x 85 x 19 mm	1
23	Countershaft bearing, 25 x 32 x 26 mm	1
24	5/16-18 x 1-1/2" SHCS, SS, polished	6
25	5/16-18 x 1-1/4" SHCS, SS, polished	2
26	Dowel pin, 3/16 x 1/2"	2
27	Transmission bearing door	1
28	Dowel pin, 1/4 x 3/4"	2
29	Bearing door gasket	1
30	Screw, 1/4-20 x 1" SHCS	1
31	Magnet, 0.250 x 0.750 x 0.250", molded	1
32	Shift assembly	1
33	Snap ring, left side case	2
34	O-ring, clutch to transmission 0480872	1
35	Mainshaft bearing, left side case	1
36	Gear set	1
37	Countershaft retaining screw 3/8-16 x 1" FHCS	1
38	Countershaft retainer washer	1

ITEM	DESCRIPTION	QTY
39	Countershaft bearing, left side case	1
40	5/16 x 3/8" Alignment pin	6
41	Speed sensor	1
42	Speedometer sensor O-ring	1
43	Speed sensor screw	1
44	1/4-20 x 1-1/4" SHCS	4
45	3/16" USS flat washer	4
46	Pillow block/shift drum assembly	1
47	Shifter pawl assembly	1
48	Shifter pawl shaft bushing	1
49	Shifter pawl seal	1
50	Shifter pawl washer	1
51	Snap ring	1
52	Fork rod	1
53	2M Shift fork	1
54	3C Shift fork	1
55	4-5 Shifter fork	1
56	5/16-24 x 1" SHCS	1
57	Shift lever, SS	1
58	1/2-20 x 1/2" setscrew (1 each end)	2
59	Shift pawl eccentric adjuster	1
60	7/16 - 14 jam nut	1
61	Needle bearing	3
62	Retaining ring	3
63	Thrust washer, 0.070"	3
64	Thrust washer, mainshaft 22.225 x 36.513 x 3.2 mm	1
65	5 th gear, mainshaft	1
66	4-5 dog clutch	1
67	4 th gear, mainshaft	1
68	Mainshaft with 1 st gear	1
69	3 rd gear, mainshaft	1
70	2 nd gear, mainshaft	1
71	Main drive gear assembly	1
72	Main drive gear seal	1
73	Spacer, countershaft gear assembly	1
74	Countershaft gear assembly	1
75	Shim (use as needed)	1

TRANSMISSION SPECIFICATIONS

INTERNAL GEAR RATIOS:

1 st	2 nd	3 rd	4 th	5 th	6 th
3.45:1	2.56:1	1.87:1	1.44:1	1.15:1	1.00:1

SHIFT PATTERN:

1st ↓ N 2nd ↑ 3rd ↑ 4th ↑ 5th ↑ 6th ↑

TORQUE VALUES

DESCRIPTION	TORQUE	LOCTITE
Bearing door screws	16 ft•lbs	2440
Top cover screws	9 ft•lbs	2440
Neutral switch	15 ft•lbs	NONE
Pillow block screws	9 ft•lbs	2440
Shifter arm screw	20 ft•lbs	2440
Pulley nut	50 ft•lbs + additional 30 to 40°	2760
Pulley nut lock screws	9 ft•lbs	2440
Shifter pawl adjuster lock nut	20 ft•lbs	2440
Drain plug	9 ft•lbs	PST 567
Countershaft screw	37 ft•lbs	2760
Transmission mounting screws	40 ft•lbs	N/A
Pulley cover screws	20 ft•lbs	2440
Ball ramp cover screws	24 in•lbs (2 ft•lbs)	2440
Clutch pushrod lock nut	30 ft•lbs	NONE

CLEARANCES

Shift drum end play	Not adjustable
Main shaft run out	0.000-0.003"
Main shaft end play	Not adjustable
Counter shaft run out	0.000-0.003"
Counter shaft end play	Not adjustable
Shift fork taper	0.000-0.020"

FLUIDS

Transmission fluid	20 oz.
--------------------	--------

NOTE: Thoroughly clean threads of all screws removed prior to assembly. Thoroughly clean internal threads at all screw locations. Use Loctite products as indicated. Use torque values specified.

BATTERY DISCONNECT

NOTE: Before performing any of the following procedures, disconnect battery, ground cable first.

WARNING! To prevent sparking, always disconnect ground cable first and reconnect last. Sparks may cause flammable substances to ignite or explode.

ADJUSTMENTS

The Balance-Drive transmission only requires two adjustments. Since the shift drum (46) rotates on a fixed spindle, no endplay shimming is required.

SHIFT LINKAGE

This adjustment will position the shifter lever.

Loosen the two jam nuts.

Visually line up shifter pedal with foot brake lever by turning the linkage.

Tighten jam nuts.

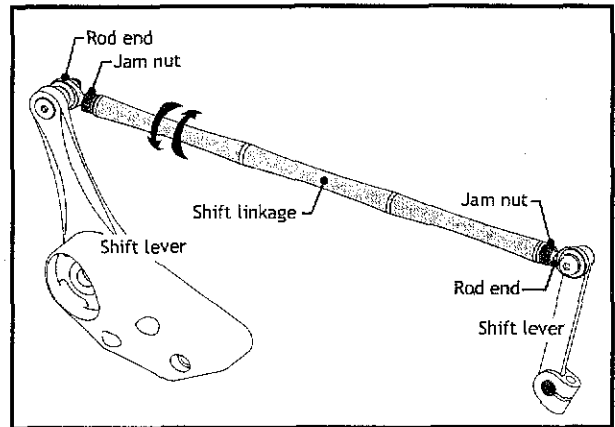

Excessive rod end wear will cause linkage noise. Replace end pivots if necessary.

SHIFTER PAWL

Shifter pawl adjustment is visual. Top cover (1) must be removed for adjustment.

Lift rear wheel.

Shift transmission into 3rd gear.

Loosen jam nut (60).

Turn shift pawl eccentric adjuster (59) clockwise or counterclockwise to obtain equal distance from center at shift lever. **NOTE: Do not apply pressure to the spring** – this will create an inaccurate adjustment.

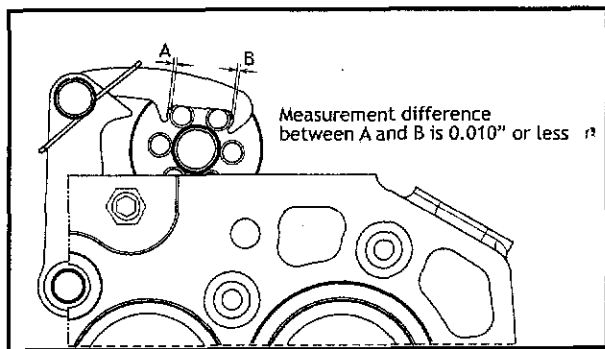

Tighten jam nut.

Install top cover (1) with a new gasket (3).

MAIN DRIVE GEAR SEALS - REMOVAL AND INSTALLATION

REMOVAL

Support the motorcycle upright and level.

Remove exhaust system.

Slide clutch cable adjuster boot away from adjusting hardware.

Turn clutch cable adjuster to provide maximum slack in cable.

Remove clutch cable from bottom frame clamp.

Remove clutch adjust cover and gasket.

Loosen clutch pushrod jam nut.

Relieve clutch pushrod tension.

Remove the three Allen screws retaining the pulley cover.

Remove pulley cover and pushrod as an assembly.

Adjust the rear wheel forward to relieve tension on the drive belt. Remove final drive belt from front pulley.

Remove pulley nut retaining screws (18).

Remove pulley nut (**left-hand thread**) (17).

Remove pulley (16).

Using a seal puller, remove main drive gear seal (72).

INSTALLATION

Install new seal using main drive gear installation tool.

Installation is reverse of removal.

Apply Loctite 2760 to pulley nut and torque to 50 ft•lbs plus and additional 30–40 degrees.

Apply Loctite 2440 to threads of pulley nut retaining screws and torque to 9 ft•lbs.

Apply Loctite 2440 to threads of pulley cover screws and torque to 20 ft•lbs.

Adjust clutch.

Adjust rear wheel and belt tension.

Reinstall exhaust.

TRANSMISSION CASE REMOVAL

Drain transmission fluid. Drain screw is located at bottom center of transmission trap door.

Remove exhaust, primary drive cover and pulley cover. Adjust the rear wheel forward to relieve tension on the drive belt. Remove final drive belt from front pulley.

Disconnect the neutral switch (5) from the transmission and remove the speed sensor (41).

Remove shift linkage from shift arm.

On Ridgeback and Pitbull models, remove the oil tank. On Chopper, Mastiff and K-9 models, remove both shocks.

Remove the six mounting screws (6) from the underside of the transmission mounting plate.

NOTE: Keep track of any transmission shims and their locations for reinstallation of transmission in frame.

Remove transmission from the frame.

IMPORTANT: Each time the left side transmission face is exposed, inspect countershaft seal (7). If seal is **not** flush with case, or if seal surface is below or beyond flush with case, remove and discard. Remove the countershaft screw (37). Thoroughly clean screw threads and internal threads at screw location. Apply Loctite 2760 to both internal and screw threads. Torque to 37 ft•lbs. Install new seal (7) flush with face of case. If seal surface is deformed during installation, remove and replace.

SHIFT DRUM REMOVAL

Remove six top cover screws (2).

Remove top cover (1) and gasket (3).

Remove the four socket head cap screws (44) and washers (45) from the pillow blocks. Gently lift the shifter pawl arm upwards.

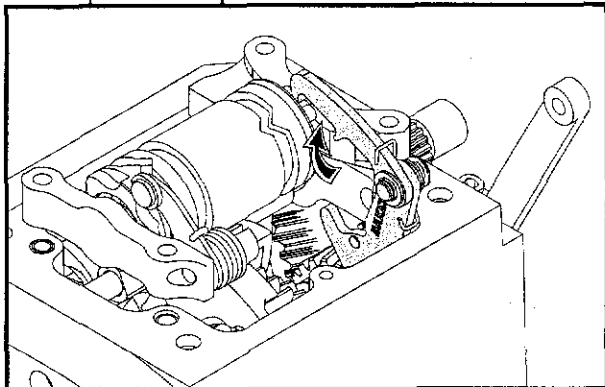

NOTE: Lifting the arm too high will damage the spring.

Lift the drum and pillow blocks as an assembly.

NOTE: Apply Loctite 2440 to threads of pillow block screws. Torque to 9 ft•lbs.

Installation is reverse of removal.

Adjust shifter pawl (47).

SHIFT FORK REMOVAL

Remove pulley cover and pulley (16).

Remove the 1/2-20 x 1/2" setscrew (58) located behind the pulley in the top center of the bearing door.

Slide out fork rod (52). **NOTE:** Center shift fork (54) must be removed first, to allow clearance for the removal of the other two shift forks.

Clean and inspect forks for wear and alignment.

Installation is reverse of removal.

NOTE: Install outer shift forks first [2M (53) and 4-5 shift fork (55)].

Install the center shift fork (3C)(54).

Ensure shift forks are fully seated in the shift fork groove on the appropriate gears. Install shift rod fork, ensuring all three shift forks move smoothly on shift fork rod.

Apply Loctite 567 thread sealant onto threads of the 1/2-20 x 1/2" setscrew (58) and install screw into transmission case (1).

GEAR SET REMOVAL

To fully service the gear set, the use of a hydraulic press and the proper press blocks is required.

Removing and installing the gears without the proper tools can cause unseen damage to the gears and shafts. **NOTE: DO NOT** use air tools.

Using a seal puller, remove the mainshaft bearing seal (8) and countershaft bearing seal (7) from the left side of the case. Discard both seals.

Lock two gear pairs together to prevent the countershaft from turning. Remove the countershaft retaining screw (37).

Remove the six 5/16-18 x 1-1/2" (24), and the two 5/16-18 x 1-1/4" bearing door screws (25). Pull bearing door away from transmission case by hand. If tight, use a slide hammer as shown below.

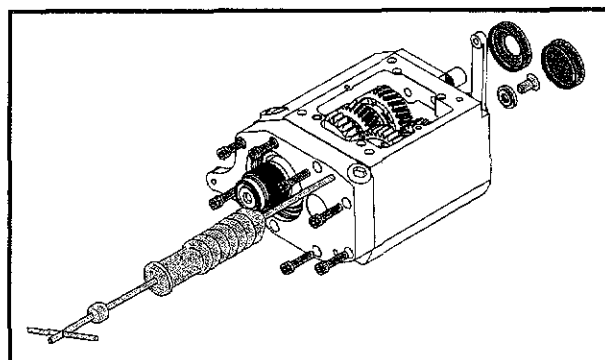

Remove 2nd mainshaft gear (70) and the 3rd mainshaft gear retaining ring (62) and thrust washer (63).

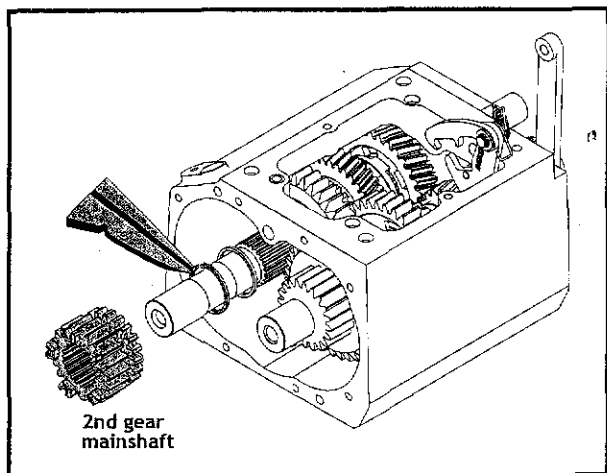

Place transmission assembly in a press, supporting assembly on the bearing door surface.

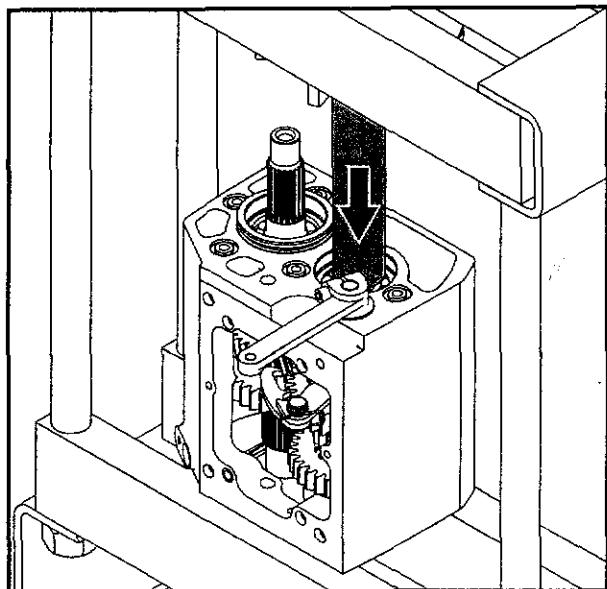

With press blocks in place, press countershaft gear assembly (74) from case. Third gear mainshaft will come out with countershaft assembly.

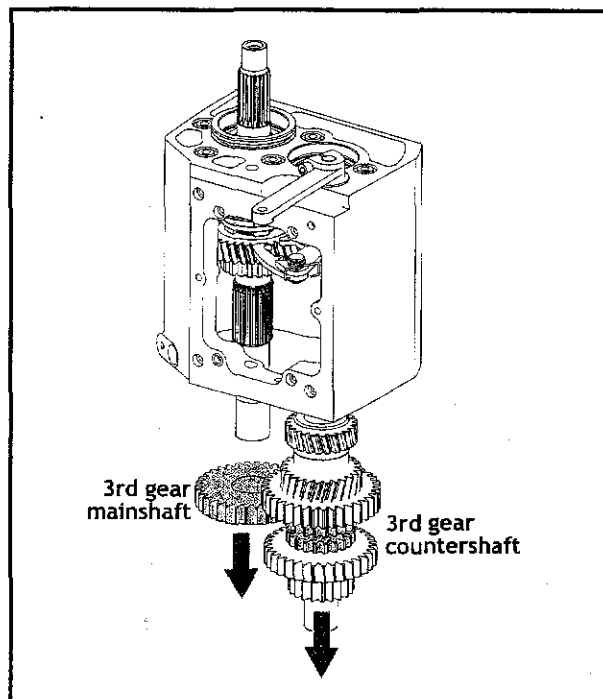

NOTE: When pressing out countershaft, do not allow 3rd gear (69) to fall from case.

After pressing countershaft gear assembly from case, continue to support case and press out the mainshaft (68).

SHIFTER PAWL - REMOVAL AND INSTALLATION

Remove retaining clip (51), washer (50) and shifter arm (57) from shifter pawl (47).

Inspect shifter pawl seal (49) and replace if needed.

Slide pawl assembly from transmission case body (4) and remove assembly from case.

Installation is reverse order of removal.

TRANSMISSION MAINSHAFT AND COUNTERSHAFT BEARING - REMOVAL ASSEMBLY AND INSTALLATION

Remove pawl.

Remove retaining rings.

Countershaft and mainshaft bearings must be replaced.

Support transmission case opposite bearing door surface and press out mainshaft and countershaft bearings.

Installation is reverse of removal.

Snap ring (33) is beveled. Beveled edge should face primary. When properly seated, distance between ring ends should measure 5/16" (0.312") or greater.

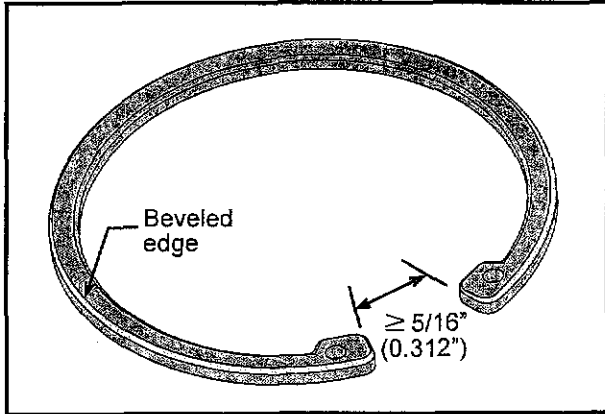

INSPECTING THE GEAR SET

Clean all gears and shafts with a degreasing agent.

Inspect each individual mainshaft gear tooth for nicks, gouges, or any uncommon wear. Replace damaged gears individually. If any gear is damaged on the countershaft gear assembly (74), replace entire assembly.

Inspect all gear and shaft bearing journals for gouging and extreme discoloration. If the bearing journals are damaged, the part must be replaced.

Inspect all male and female dog teeth and replace gears if excessive wear is present.

The 4th and 5th countershaft gears are pressed onto the countershaft with a 0.003" interference fit.

The countershaft gears and the countershaft are to be replaced as an assembly.

ASSEMBLING GEAR CLUSTERS

NOTE: When installing the gear clusters, only use new retaining rings (62).

Assemble the mainshaft gear clusters using the exploded view parts diagram for proper gear placement.

The 4-5 dog clutch (66) is directional. The side with the smaller diameter flange must be facing the mainshaft 4th gear (67).

NOTE: Do not install the 3rd gear mainshaft (69) at this time.

ASSEMBLING THE TRANSMISSION

Install shifter pawl assembly (47) in case.

Place mainshaft assembly (68) in press, put case over mainshaft and press case onto mainshaft assembly by pressing bearing inner race. Support mainshaft assembly, not case.

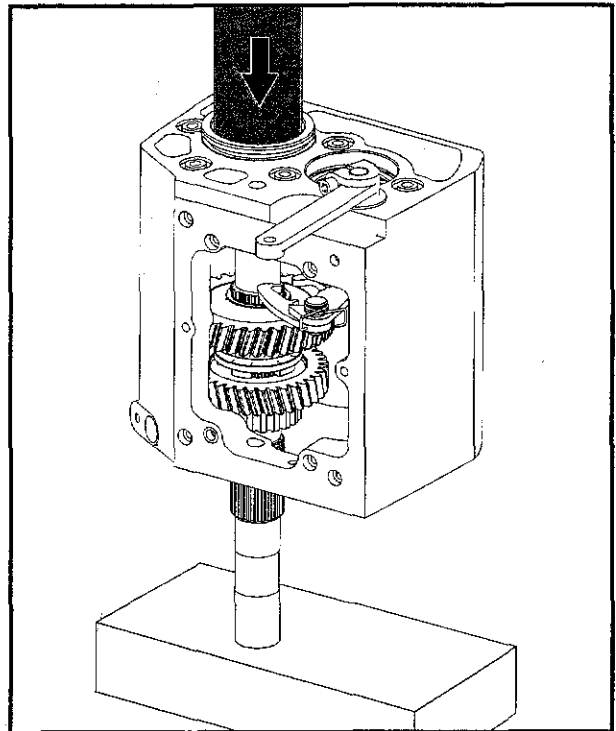

Install countershaft gear assembly (74) and 3rd gear (69) from mainshaft in reverse order of removal.

IMPORTANT: Ensure mainshaft gear and countershaft gears are meshed before pressing case onto countershaft to prevent gear tooth damage.

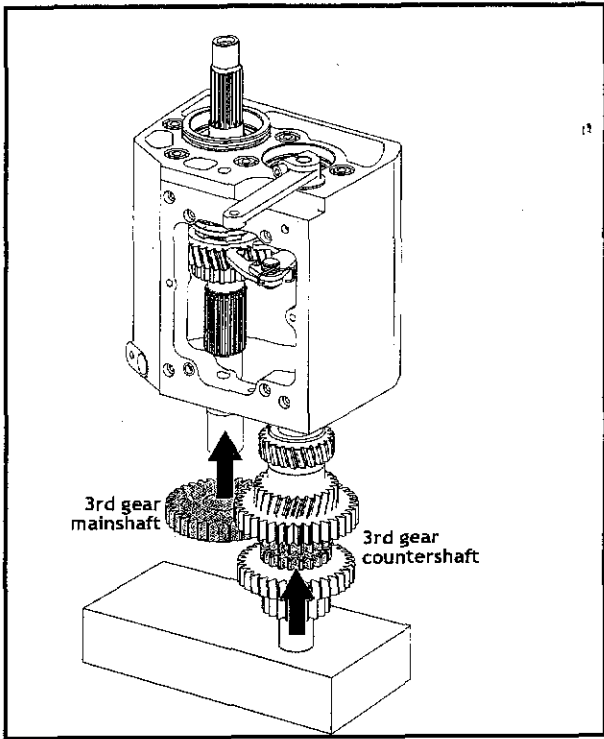

After gear clusters have been pressed into the case, install mainshaft 2nd gear (70).

Apply Loctite 2440 to screw threads and install the transmission bearing (27) door. Torque screws (24, 25) to 16 ft•lbs.

Lock gears and install the countershaft retainer washer (38). Apply Loctite 2760 liberally to the countershaft retaining screw (37) and hole threads and torque to 37 ft•lbs.

Install shift forks and shift drum. Adjust shifter pawl.

If needed to properly align primary chain, install shim (75) between the mainshaft bearing race (35) and the clutch sealing O-ring (34). Motor sprocket and motor clutch sprocket ideal alignment is within ± 0.020 ".

Install the left side mainshaft seal (8) and countershaft seal (7). Install countershaft seal (7) flush with transmission case, using care to not indent the center of the seal.

Liberally coat gears and shift drum with assembly lube.

Shift through gears to ensure proper operation.

Install new top cover gasket (3). Apply Loctite 2440 to screw threads and reinstall top cover (1). Torque screws (2) to 9 ft•lbs.

Position the transmission in frame. If any shims were removed, reinstall them in their previous locations.

Reattach neutral safety switch (5).

Reinstall speed sensor (41). Apply Loctite 2440 to sensor retaining screw (43) and torque to 9 ft•lbs.

Refer to *Chassis* Chapter for drive train alignment procedure.

Handwritten notes in the right margin:

50	1	4	
	0	0	
50	2	5	0
	0	0	0
			0